

# Magneto-strictive, Magneto-rheological & Ferrofluidic Materials

Corso Materiali intelligenti e Biomimetici  
2/04/2020

*ludovica.cacopardo@ing.unipi.it*

# Magnetic Properties

**Magnetic Permeability:** indicates **how easily a material can be magnetized**. It is a constant of *proportionality* that exists between *magnetic induction* and *magnetic field intensity*.

$\mu_r = \mu / \mu_0$  (relative permeability)  
 $\mu_0 = 1.26 \times 10^{-6}$  H/m in free space (vacuum)

- Materials that cause the lines of flux to move farther apart, resulting in a **decrease in magnetic flux density** compared with a vacuum, are called **diamagnetic**;
- materials that **concentrate magnetic flux** are called **paramagnetic** (non-ferrous metals such as copper, aluminum);
- materials that concentrate the flux by a factor of more than ten are called **ferromagnetic** (iron, steel, nickel).

$$B = \mu H$$

INDUZIONE MAGNETICA [T] = [N / A m]      CAMPO MAGNETICO [A / m]      [N / A<sup>2</sup>]

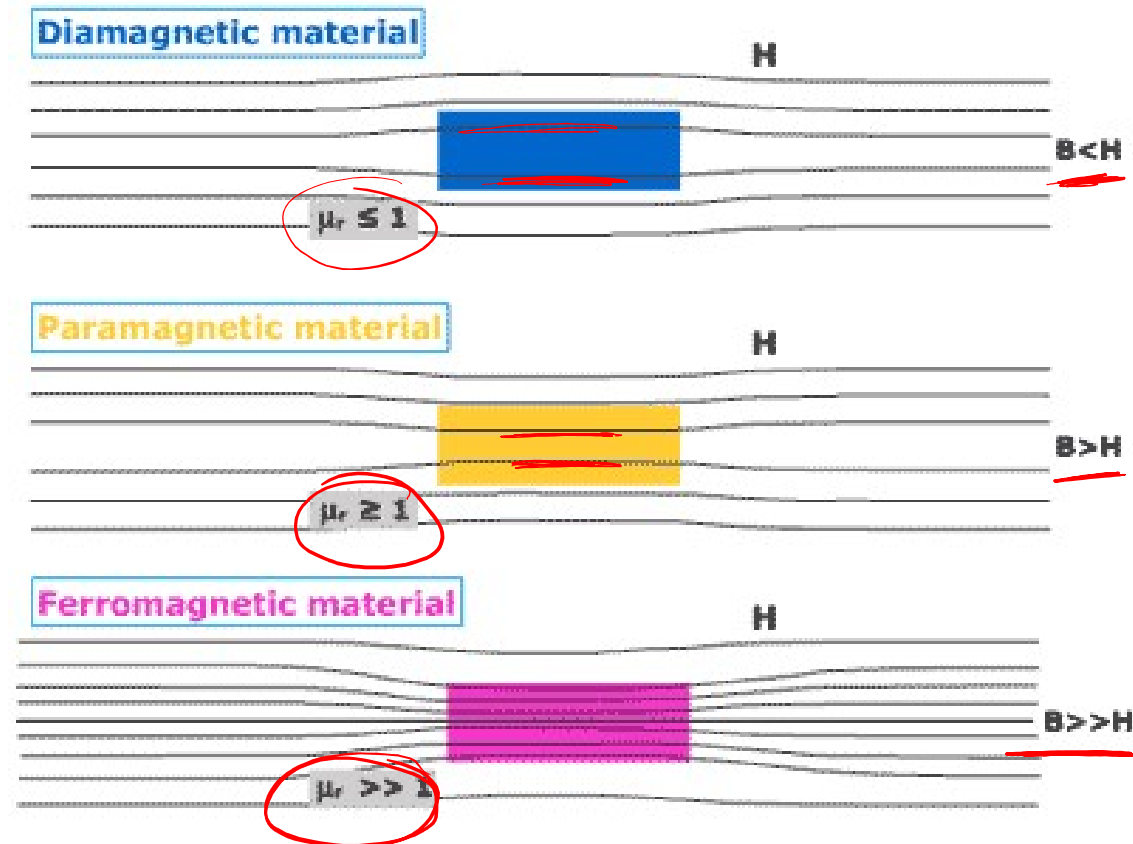

# Magnetic Properties

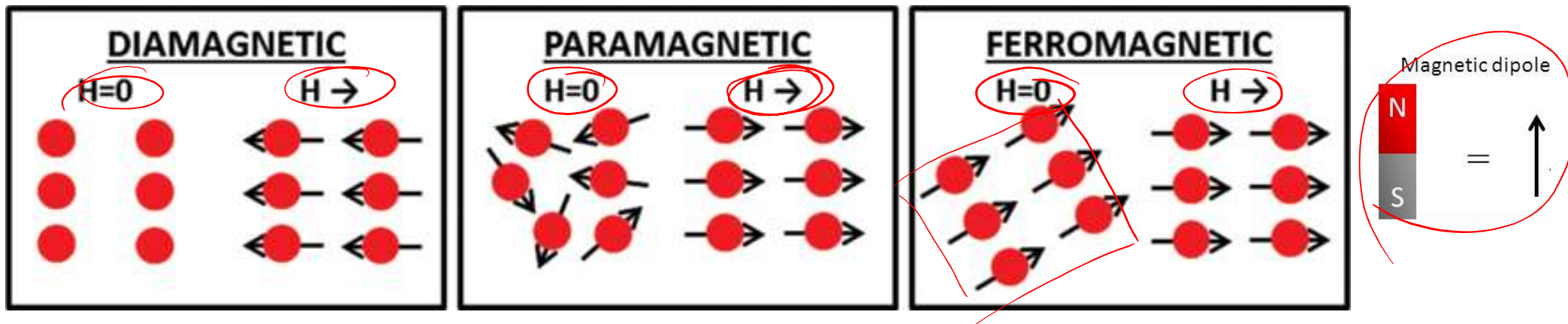

- **Diamagnetic:** *dipoles formed* under the applied field  $H \rightarrow$  oriented in an **opposite direction** with respect to the applied  $H$  (no net magnetization)
- **Paramagnetic:** *existing random dipoles*  $\rightarrow$  oriented in the **same direction** of the applied  $H$  (small magnetization)
- **Ferromagnetic:** *existing aligned dipoles*  $\rightarrow$  oriented in the **same direction** of the applied  $H$  (large magnetization)

Magnetic Property	Direction of Polarization (I) Relative to External Field	Relative Magnetic Susceptibility ( $\chi$ ) in ppm	Typical Materials
Diamagnetism	Opposite	-10	Water, fat, calcium, most biologic tissues
Paramagnetism	Same	+1	Molecular $O_2$ , simple salts and chelates of metals (Gd, Fe, Mn, Cu), organic free radicals
Superparamagnetism	Same	+5000	Ferritin, hemosiderin, SPIO contrast agents
Ferromagnetism	Same	> 10,000	Iron, steel

Magnetic field absent

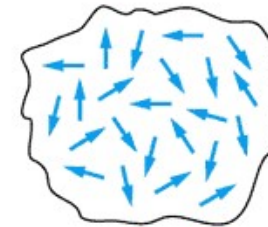

In presence of magnetic field

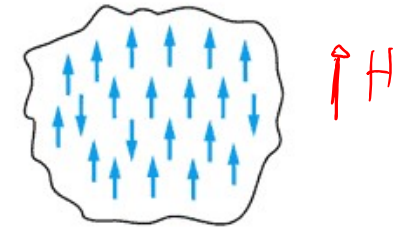

Paramagnetism

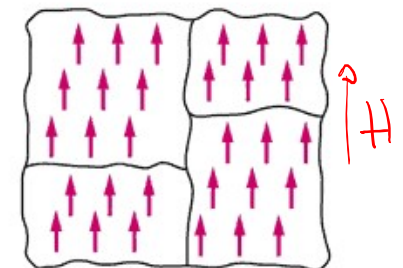
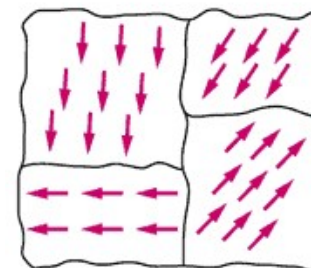

domains

Ferromagnetism

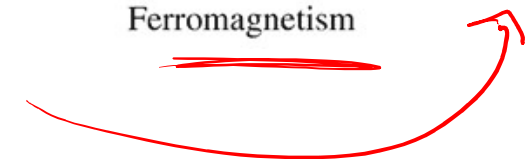

# Magneto-strictive materials (MS)

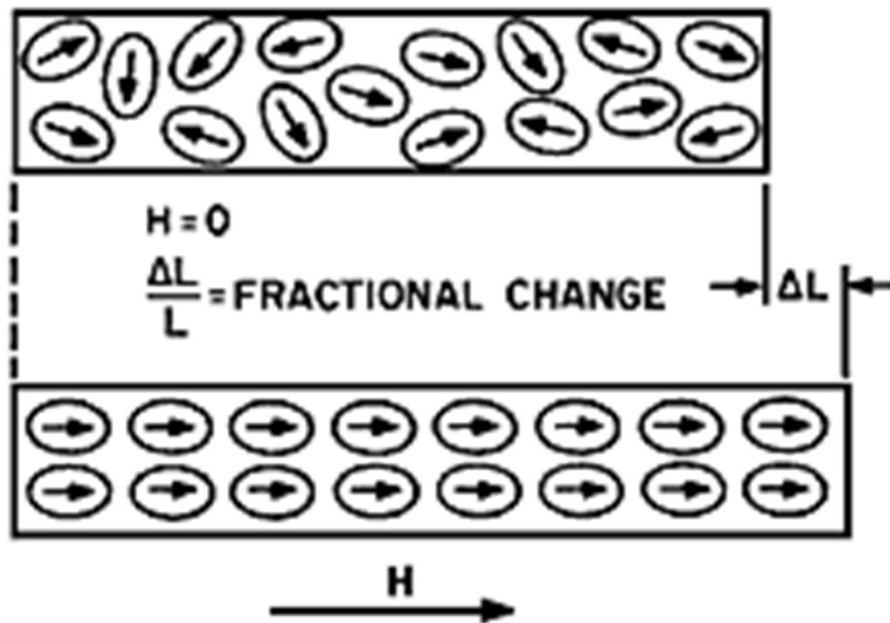

**Ferromagnetic materials** have a structure that is divided into **domains** (regions of uniform magnetic polarization).

When a magnetic field is applied, the **domains rotate** causing **a change in the material dimensions.**

Magnetostriction is a property of ferromagnetic materials that causes them to **change in shape** of materials under the influence of an **external magnetic field**.

Magnetostriction is a reversible exchange of energy between the mechanical and the magnetic domain (**magneto-mechanical coupling**).

# Magnetostriction

The reason that a rotation of the magnetic domains of a material results in a change in the materials dimensions is a consequence of **magneto-crystalline anisotropy**: *it takes more **energy to magnetize a crystalline material in one direction than another.***

If a magnetic field is applied to the material at an angle to an easy axis of magnetization, *the material will tend to rearrange its structure so that an easy axis is aligned with the field to **minimize the free energy of the system.***

Since **different crystal directions are associated with different lengths** this effect induces a strain in the material.

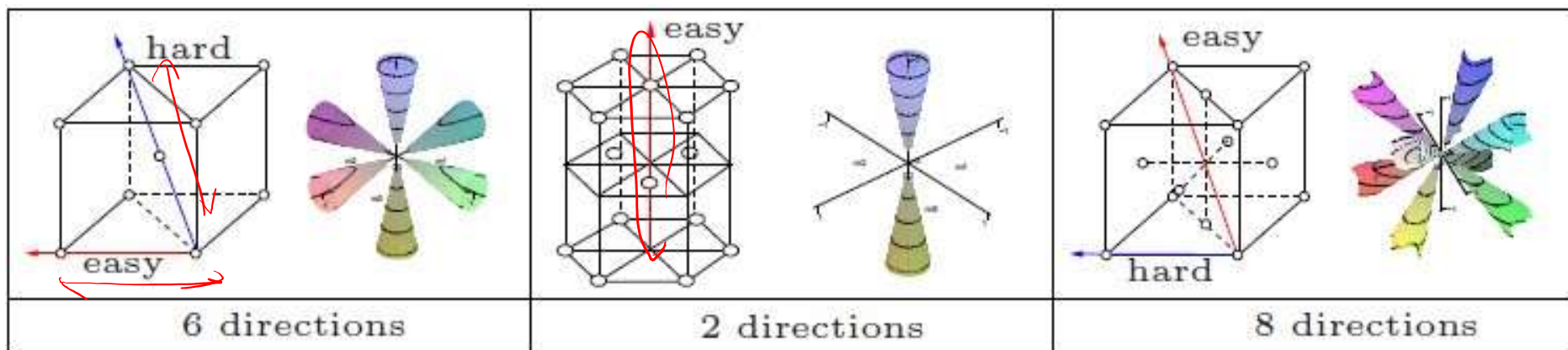

# Curie Temperature

When the material is above its Curie temperature, it exists in a **paramagnetic state** and is composed of unordered **magnetic moments in random orientations**.

On cooling below the Curie temperature (*spontaneous polarization*), the material becomes **ferromagnetic**, and the **magnetic moments become ordered over small volumes** (domains).

However, because the domains are randomly oriented, the **net magnetization of the material is zero**.

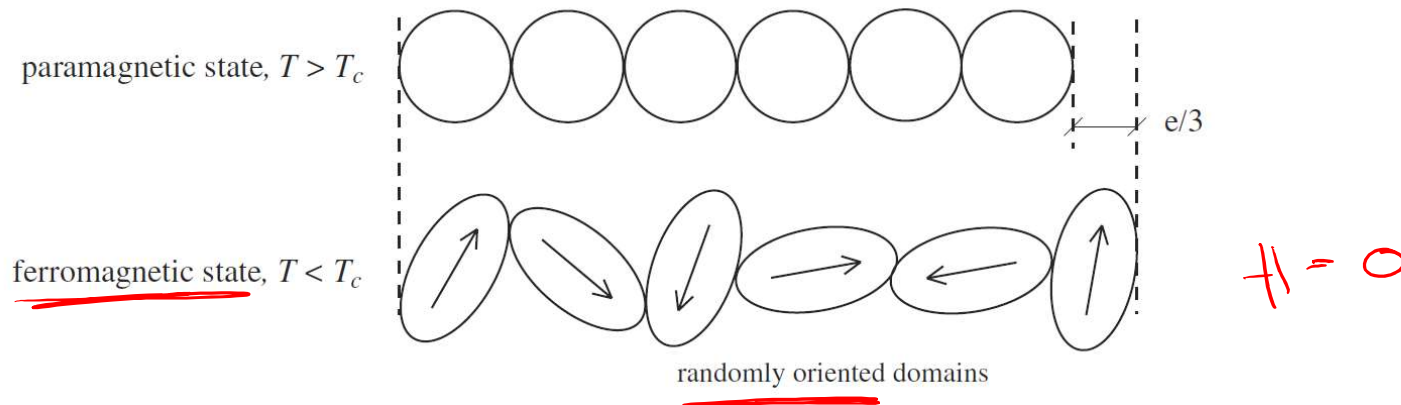

# Field-induced Magnetostriction

Applying a **magnetic field below the Curie temperature**, leads to domains re-orientation in the direction of magnetic field and to a global deformation of the material.

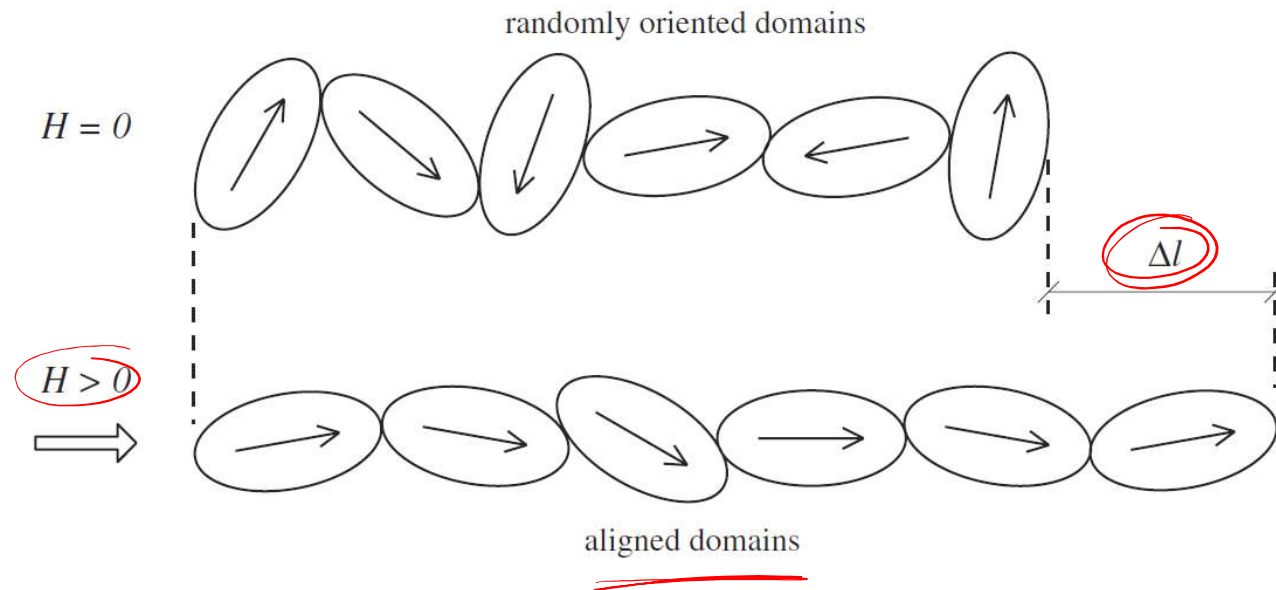



# Strain vs. Magnetic field

Region 0-1: domains start to align (non linear relationship)

Region 1-2: almost **linear relationship between strain and magnetic field** (most devices are designed to operate in this region).

Region ~~1-2~~ **1-3**: the **relationship becomes non-linear** since most of the magnetic domains have become aligned with the magnetic field direction (the increase of magnetic field is no more proportional with the strain).

Beyond point 3: **saturation** (all the magnetic domains have become aligned with the magnetic field and no further strain is achievable)

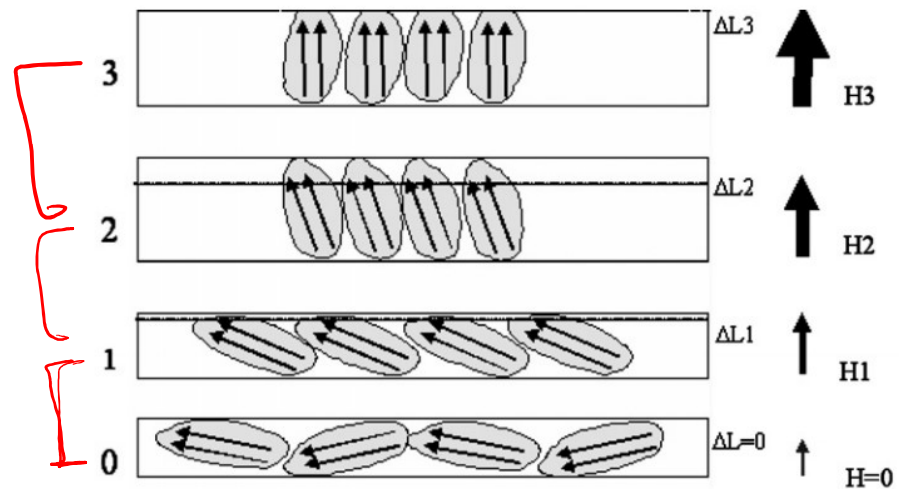
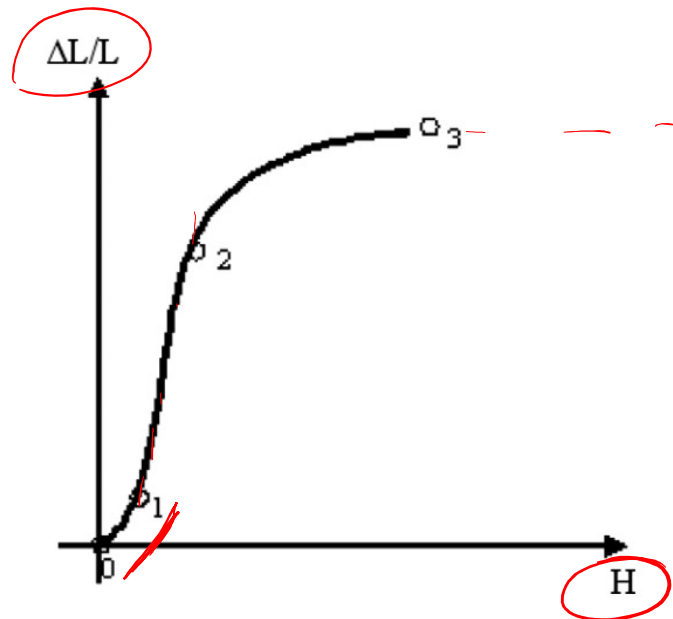

# Strain vs. Magnetic field (2)

When a **magnetic field** is established in the **opposite direction**, the negative field produces the **same elongation** in the magnetostrictive material (*strain direction is independent from magnetic field polarity*). For its shape, the curve strain vs. magnetic field curve is referred as **butterfly curves**.

The **positive** (expansion) or **negative magnetostriction** (contraction) of the material depends on material intrinsic properties.

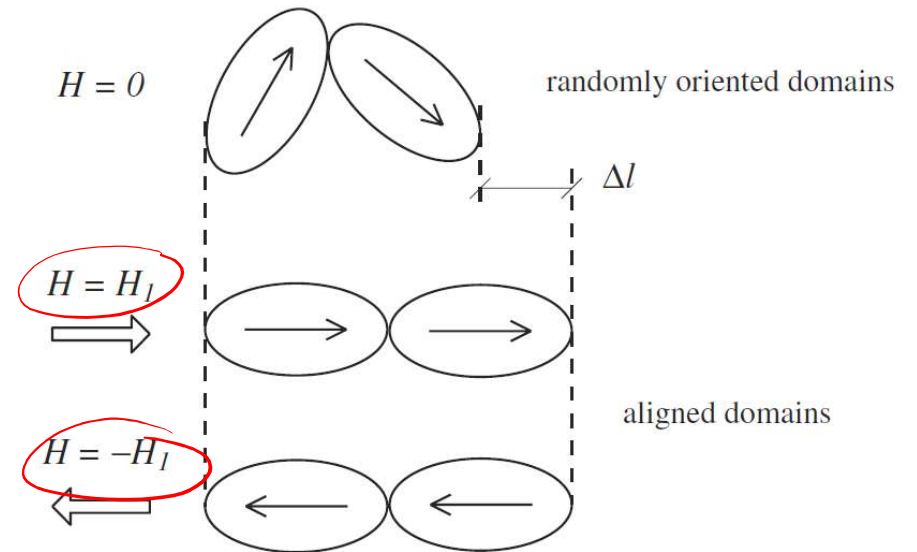
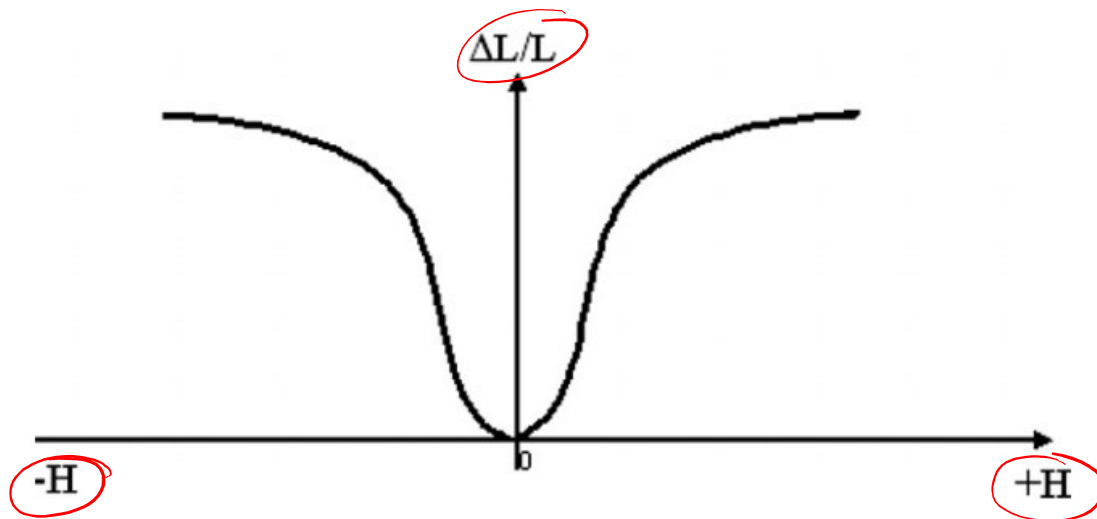

# Magnetostriction in pre-stressed conditions

If the material is **pre-stressed**, *the recoverable strain is larger*.

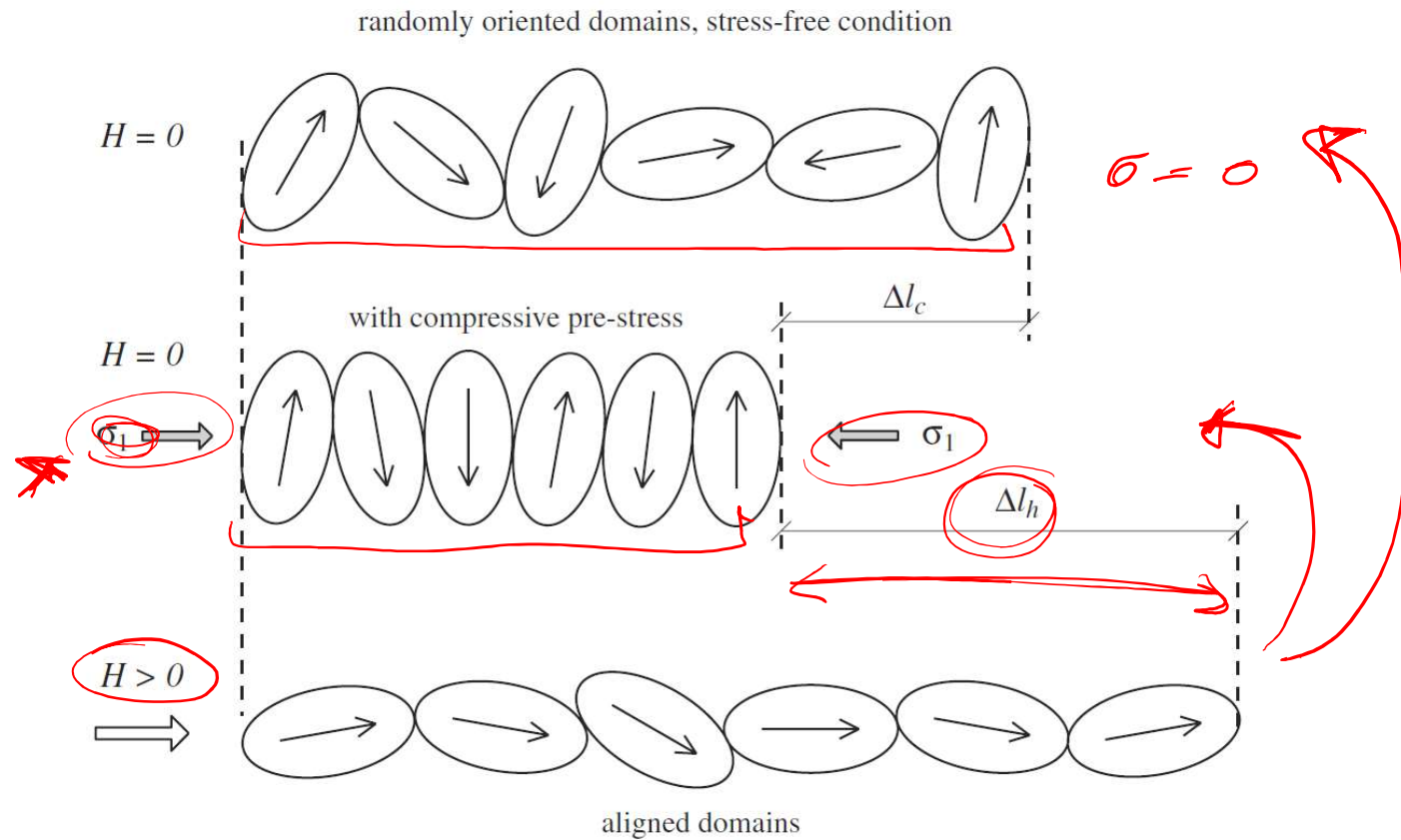

# (Main) Magnetostrictive Effects

The **Joule Effect** is related to material deformation under an external magnetic field.

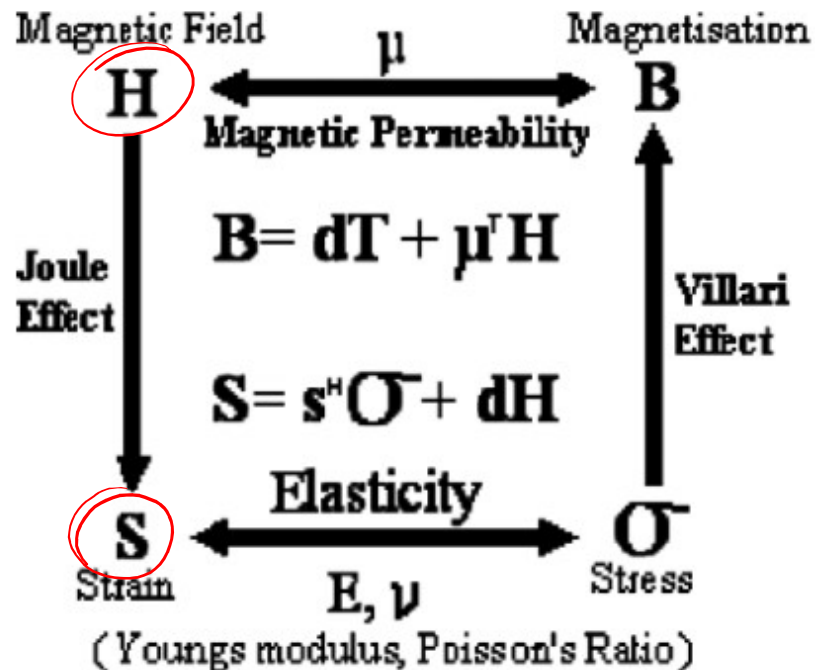

The **Villari Effect** is a change of the magnetic properties of a material when subjected to a mechanical stress.

The change in the magnetic flux density can be detected by a pickup coil and is proportional to the level of the applied stress.

## EFFETTO LOUKE

$$\varepsilon = c^H \sigma + d H$$

$c^H$  compliance  $[Pa^{-1}] [Pa]$   
 $d$  cost. magnetostrizione  $[\frac{m}{A}] [\frac{A}{m}]$   
 $H$  campo M.

## EFFETTO VILKARI

$$B = d \sigma + \mu^H H$$

$d$  Induzione  $[\frac{N}{Am}]$   
 $\mu^H$  permeabilità magnetica  $[\frac{N}{A^2}] [\frac{A}{m}]$   
 $H$  campo M.

# Sensor Rod

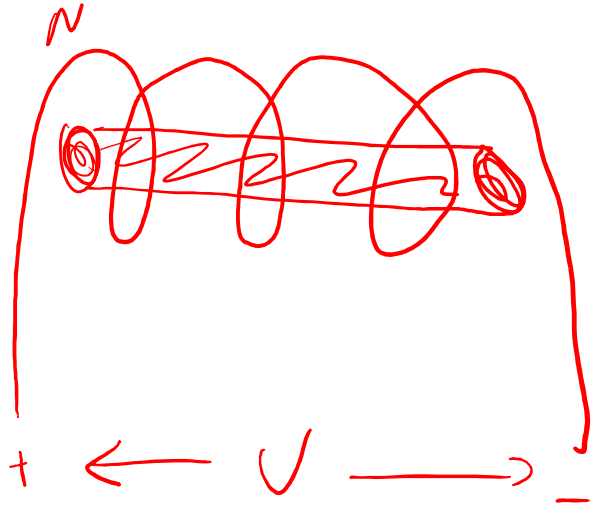

$$dU = - N \frac{d\phi}{dt} = - NA \frac{dB}{dt} \propto \underline{dv}$$

$$\phi = BA$$

# 3D example

For Terfenol-D, it has been theoretically proven that the coefficient matrices in the piezomagnetic equations can be expanded as

$$\begin{Bmatrix} \epsilon_1 \\ \epsilon_2 \\ \epsilon_3 \\ \gamma_{23} \\ \gamma_{31} \\ \gamma_{12} \end{Bmatrix} = \begin{bmatrix} s_{11}^H & s_{12}^H & s_{13}^H & 0 & 0 & 0 \\ s_{12}^H & s_{11}^H & s_{13}^H & 0 & 0 & 0 \\ s_{13}^H & s_{13}^H & s_{33}^H & 0 & 0 & 0 \\ 0 & 0 & 0 & s_{44}^H & 0 & 0 \\ 0 & 0 & 0 & 0 & s_{44}^H & 0 \\ 0 & 0 & 0 & 0 & 0 & s_{66}^H \end{bmatrix} \begin{Bmatrix} \sigma_1 \\ \sigma_2 \\ \sigma_3 \\ \tau_{23} \\ \tau_{31} \\ \tau_{12} \end{Bmatrix} + \begin{bmatrix} 0 & 0 & d_{31} \\ 0 & 0 & d_{31} \\ 0 & 0 & d_{33} \\ 0 & d_{15} & 0 \\ d_{15} & 0 & 0 \\ 0 & 0 & 0 \end{bmatrix} \begin{Bmatrix} H_1 \\ H_2 \\ H_3 \end{Bmatrix} \quad (6.64)$$

$$\begin{Bmatrix} B_1 \\ B_2 \\ B_3 \end{Bmatrix} = \begin{bmatrix} 0 & 0 & 0 & 0 & d_{15}^* & 0 \\ 0 & 0 & 0 & d_{15}^* & 0 & 0 \\ d_{31}^* & d_{31}^* & d_{33}^* & 0 & 0 & 0 \end{bmatrix} \begin{Bmatrix} \sigma_1 \\ \sigma_2 \\ \sigma_3 \\ \tau_{23} \\ \tau_{31} \\ \tau_{12} \end{Bmatrix} + \begin{bmatrix} \mu_{11}^\sigma & 0 & 0 \\ 0 & \mu_{11}^\sigma & 0 \\ 0 & 0 & \mu_{33}^\sigma \end{bmatrix} \begin{Bmatrix} H_1 \\ H_2 \\ H_3 \end{Bmatrix} \quad (6.65)$$

Let us consider a one-dimensional rod with magnetic field aligned along the longitudinal axis (axis-3). The constitutive equations (Eqs. 6.59 and 6.60) can be written as

$$\epsilon_3 = s_{33}^H \sigma_3 + d_{33} H_3 \quad (6.78)$$

$$B_3 = d_{33}^* \sigma_3 + \mu_{33}^\sigma H_3 \quad (6.79)$$

Table 6.5. Nominal properties for a Terfenol-D rod

Nominal Composition	-	Tb <sub>0.3</sub> Dy <sub>0.7</sub> Fe <sub>1.92</sub>
Maximum field induced magnetostriction, $\mu\epsilon$	$\Lambda_s$	1740
Young's Modulus, constant field, MPa	$E^H$	35-50
Young's Modulus, constant induction, MPa	$E^B$	40-65
Magnetic permeability, constant stress, Tm/A	$\mu^\sigma$	$3-10 \times 10^{-6}$
Relative permeability	$\mu_r$	5-10
Saturation magnetization, A/m	$M_s$	$0.79 \times 10^6$
Magnetostrictive coefficient, m/A	$d$	$3-20 \times 10^{-9}$
Magnetomechanical coupling factor	$k$	0.7-0.75
Density, kg/m <sup>3</sup>	$\rho$	9250
Resistivity, $\Omega\text{m}$	$\varrho$	$60 \times 10^{-8}$
Coefficient of thermal expansion, ppm/°C	$\alpha_T$	12
Compressive strength, MPa	-	≈700
Tensile strength, MPa	-	≈28
Curie Temperature, °C	$T_c$	380

$$c^H = \frac{1}{\epsilon^H}$$

|



# Terfenol rod '33-mode'

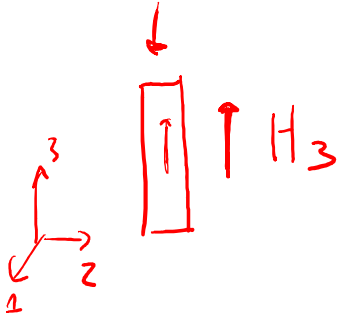

$$\epsilon_3 = C_{33}^H \sigma_3 + d_{33} H_3 \rightarrow \sigma_3 = \frac{\epsilon_3}{C_{33}^H} - \frac{d_{33}}{C_{33}^H} H_3$$

$$B_3 = d_{33} \sigma_3 + M_{33}^\sigma H_3$$

$$B_3 = d_{33} \left( \frac{\epsilon_3}{C_{33}^H} - \frac{d_{33}}{C_{33}^H} H_3 \right) + M_{33}^\sigma H_3$$

$$= \frac{d_{33}}{C_{33}^H} \epsilon_3 + \left( M_{33}^\sigma - \frac{d_{33}^2}{C_{33}^H} \right) H_3$$

coeff. accoppiamento  
magneto meccanico

$$0 \leq k \leq 1$$

$$M^\epsilon < M^\sigma$$

$$M_{33}^\epsilon = M_{33}^\sigma \cdot \left( 1 - \frac{d_{33}^2}{C_{33}^H M_{33}^\sigma} \right)$$

# Numerical Example: actuator terfenol rod

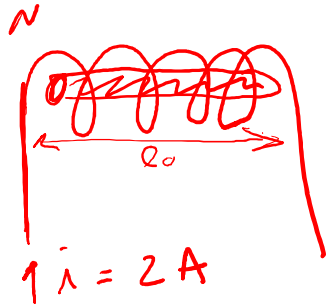

$$l_0 = 50.8 \text{ mm}$$
$$d = 6.35 \text{ mm}$$
$$N = 1000$$

$$d_{33} = 20 \times 10^{-9} \text{ m/A}$$

$$\mu_{33}^{\sigma} = 11.56 \times 10^{-6} \text{ H/m (VIB/Am)}$$

$$K_{33} = 0.72$$

i)  $\Delta l$

$$H_3 = \frac{Ni}{l} = \frac{1000 \cdot 2 \text{ A}}{0.0508 \text{ m}} = 39.37 \text{ k} \frac{\text{A}}{\text{m}}$$

$$\underline{\underline{\sigma_3 = \sigma}} \Rightarrow \underline{\underline{\epsilon_3}} = d_{33} H_3 = 20 \times 10^{-9} \frac{\text{m}}{\text{A}} \times 39.37 \frac{\text{kA}}{\text{m}} = \underline{\underline{787 \mu\epsilon}}$$

$$\Delta l = \epsilon_3 l_0 = 0.04 \text{ mm}$$

2)  $\Phi$ ? ( $\sigma_3 = \emptyset$ )

$$B_3 = M_{33}^r H_3 = 11.56 \times 10^{-6} \frac{\text{Wb}}{\text{Am}} \times 39.37 \text{ k} \frac{\text{A}}{\text{m}} = 0.45 \text{ T}$$

$$\Phi = B_3 A = 0.45 \text{ T} \times \pi \left( \frac{6.35 \times 10^{-3}}{2} \right)^2 \text{ m}^2 = 14.41 \times 10^{-6} \text{ Tm}^2$$

3)  $\mathcal{L}$  (INDUTTANZA)?

$$\mathcal{L}_{33}^{\sigma=0} = M_{33}^{\sigma=0} \frac{\text{N}^2 \text{ A}}{\text{e}} = 11.56 \times 10^{-6} \frac{\text{H}}{\text{m}} \cdot (1000)^2 \cdot \frac{\pi \left( \frac{6.35 \times 10^{-3}}{2} \right)^2 \text{ m}^2}{0.0508 \text{ m}} = 7.21 \text{ mH}$$

$$\mathcal{L}_{33}^{\epsilon} = \mathcal{L}_{33}^{\sigma=0} (1 - k_{33}^2) = 3.67 \text{ mH}$$

# Example of MS materials

- **Cobalt** exhibits a room-temperature magnetostriction of **60 microstrains** in a field of **160 kA/m**
- **Cobalt alloys: Terfenol-D** (*Ter for terbium, Fe for iron, NOL for Naval Ordnance Laboratory, and D for dysprosium*) exhibits about **2000 microstrains** in a field of **160 kA/m** at room temperature and is the most commonly used engineering magnetostrictive material.



# MS properties

Table 1  
Technology features overview [1,2,8–11]

Typical features	PZT	Terfenol-D	SMA
Actuation mechanism	Piezoelectric material	Magnetostrictive material	Shape memory alloys
Elongation	0.1%	0.2%	5%
Energy density	2.5 kJ/m <sup>3</sup>	20 J/m <sup>3</sup>	1 J/m <sup>3</sup> *
Bandwidth	100 kHz	10 kHz	0.5 kHz
Hysteresis	10%	2%	30%
Costs as reference	200 \$/cm <sup>3</sup>	400 \$/cm <sup>3</sup>	200 \$/cm <sup>3</sup>

# Application example: Linear MS actuator

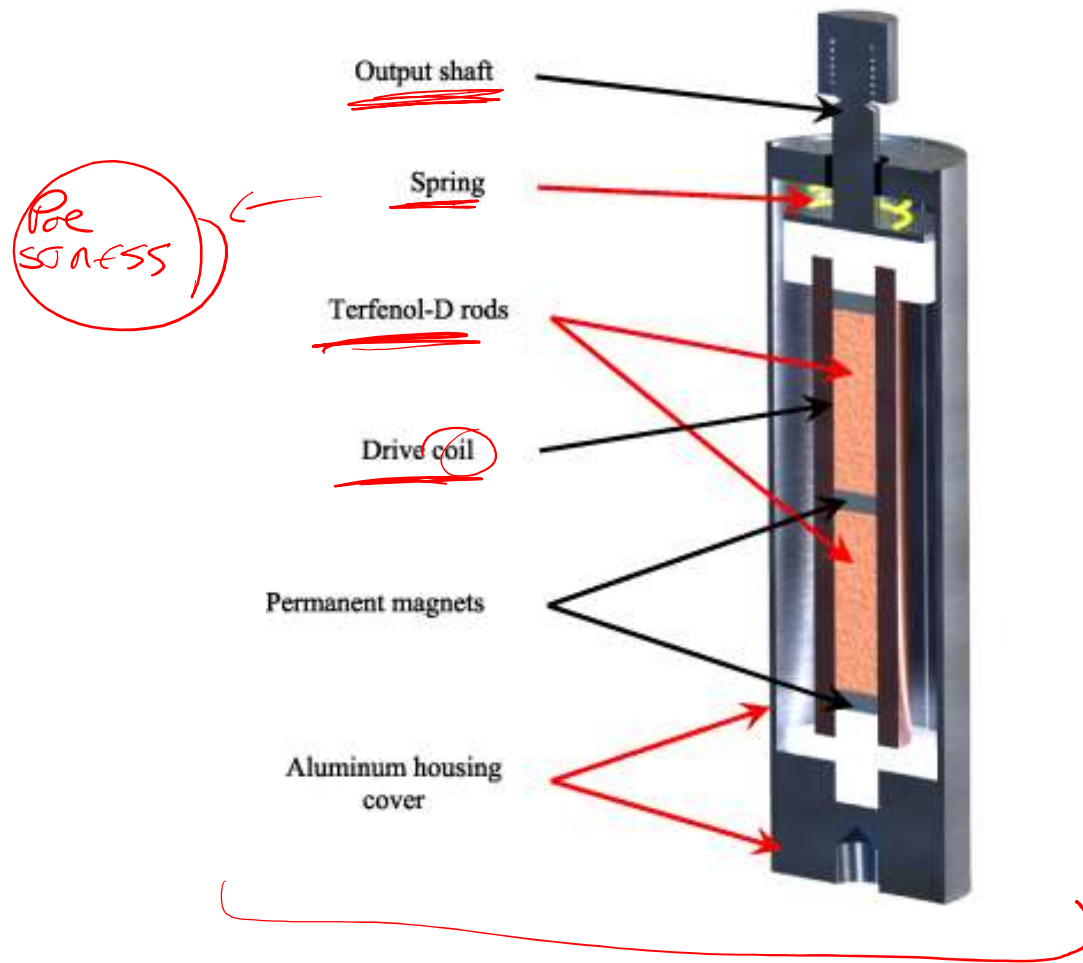

# Application example(2): MS inchworm motor

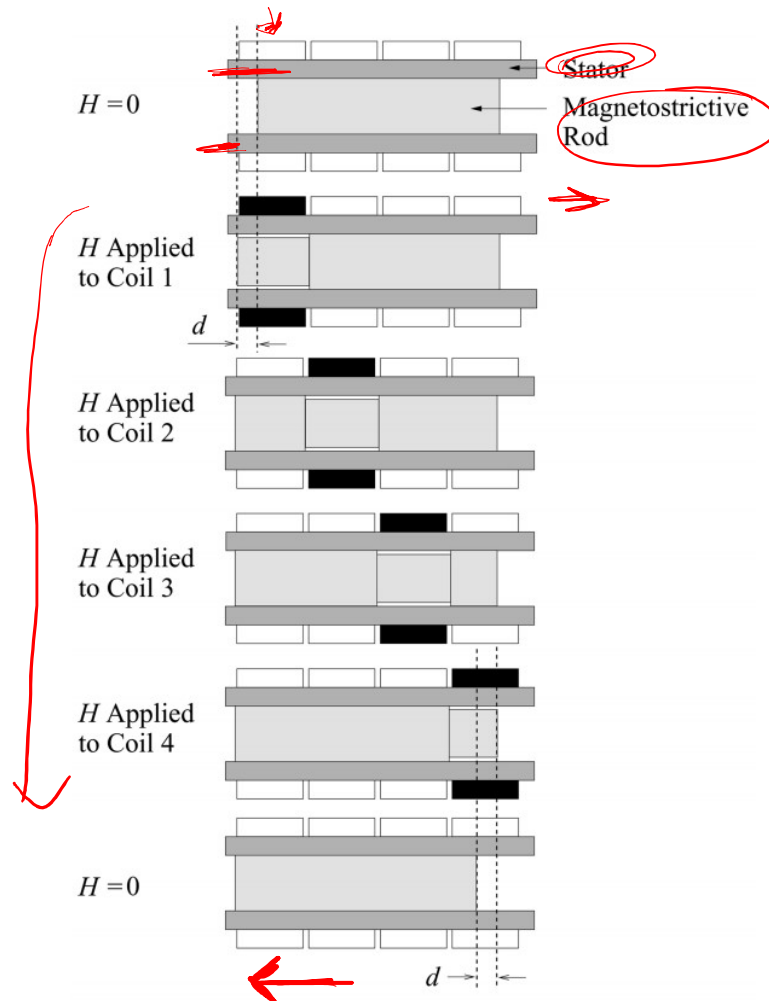

When one of the *coils* is *energized*, the section of rod directly exposed to the magnetic field **elongates**.

As the field is removed, the **rod clamps itself again inside the stator** but **at a distance  $d$**  to the left of the original position.

As the remaining coils are energized sequentially, *the rod moves in the direction opposite to the sweeping field*. The **direction of motion is changed by inverting the coil activation sequence**.

# Magneto-rheological (MR) materials

Micrometric (0.1–10  $\mu\text{m}$  range) **ferromagnetic particles** randomly *dispersed in oil or water*. MR fluid particles are too dense for Brownian motion to keep them suspended, thus surfactants are included in the mixture to avoid the settling of the suspended particles.

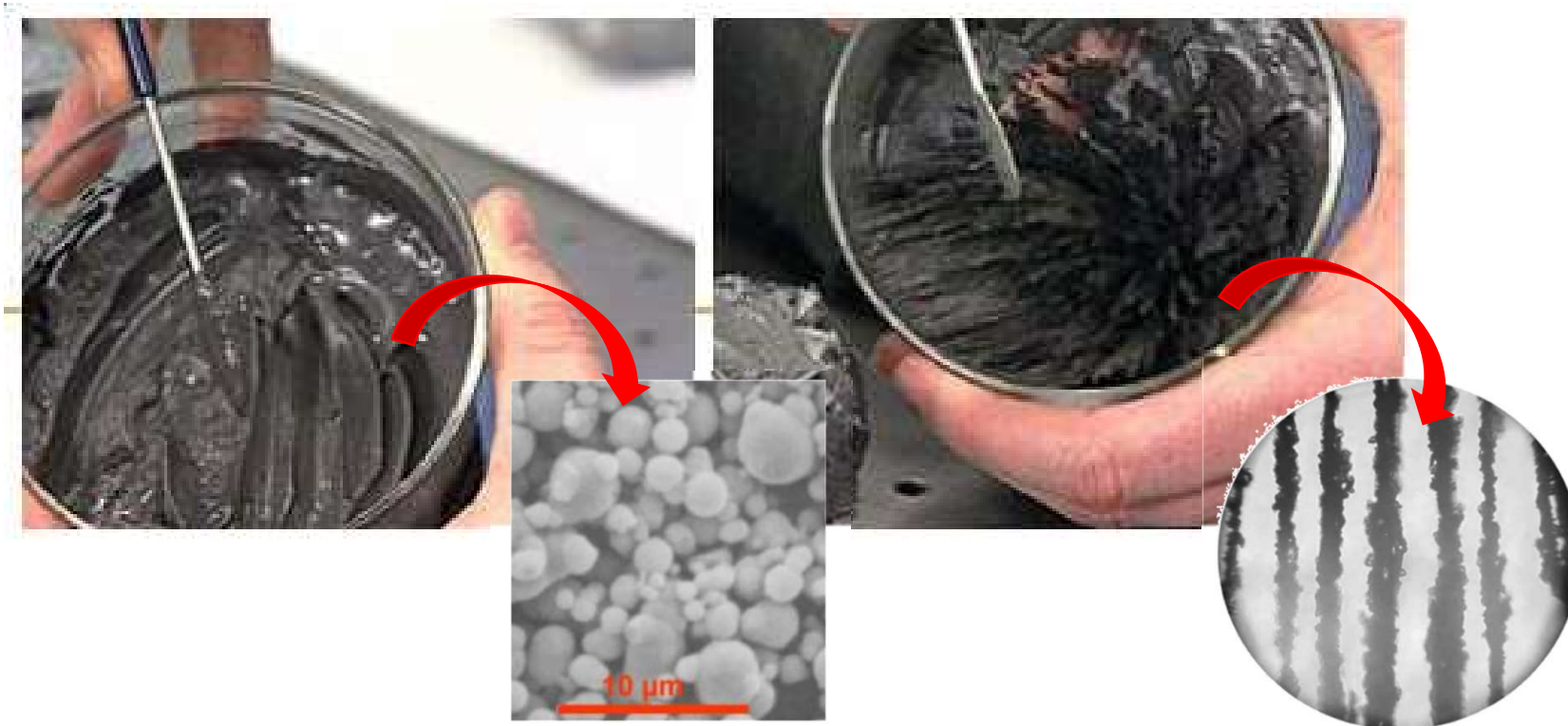



# MR materials: behaviour

When subjected to a *magnetic field*, the ferromagnetic particles align their magnetic dipoles along the lines of magnetic flux. These **microscopic chains** have the *macroscopic effect* to change fluid **viscosity** to the point of becoming a *viscoelastic solid*.

The main advantage of MR materials is that the amount of **dissipated energy** of the system is simply **controllable** by acting on the coil current and the system can provide **semi-active damper** behaviour.

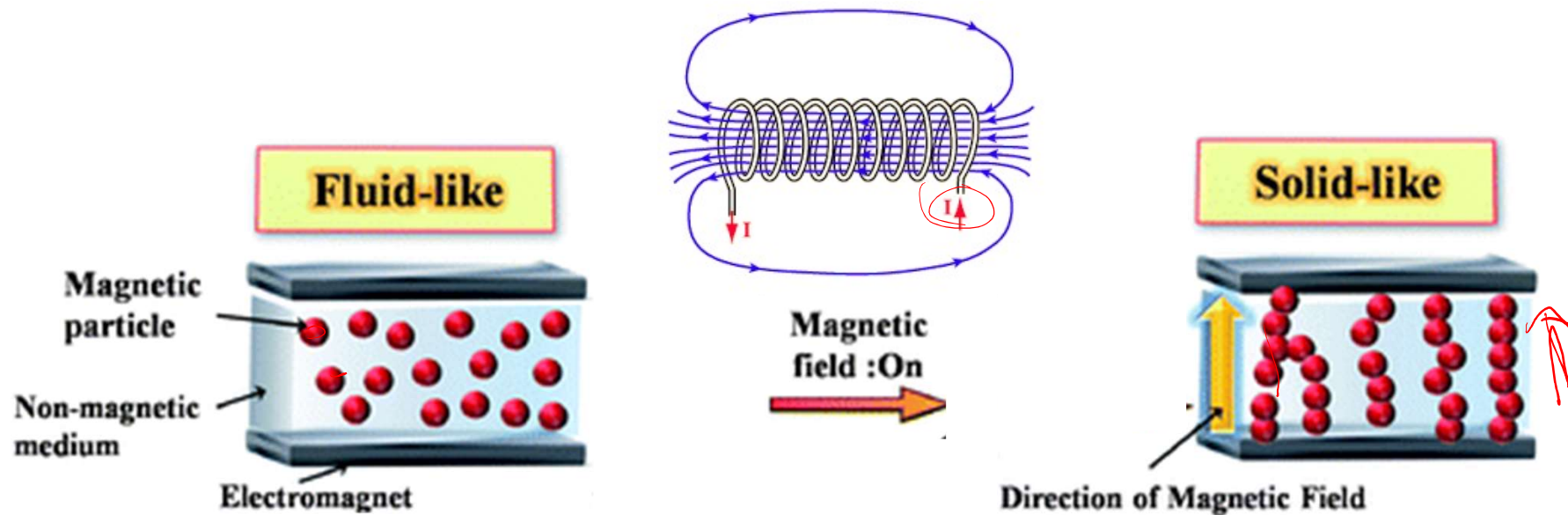

# MR materials: rheological properties

The MR fluid behaves following a **Bingham** law with a **yield shear stress** (critical stress at which the material start to flow).

In the MR fluids, the value of the yield stress is **controlled by the applied magnetic field**: *the larger the field, the higher the yield stress* and thus **the force the material can withstand without flowing**.

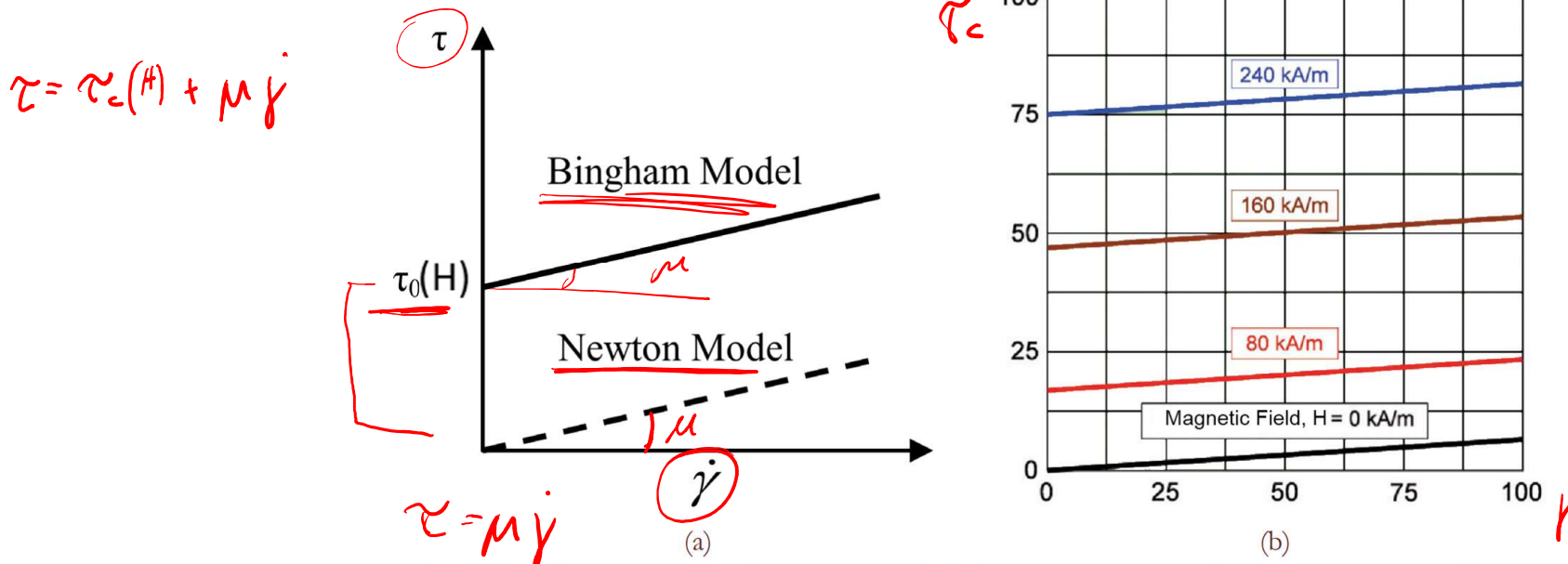
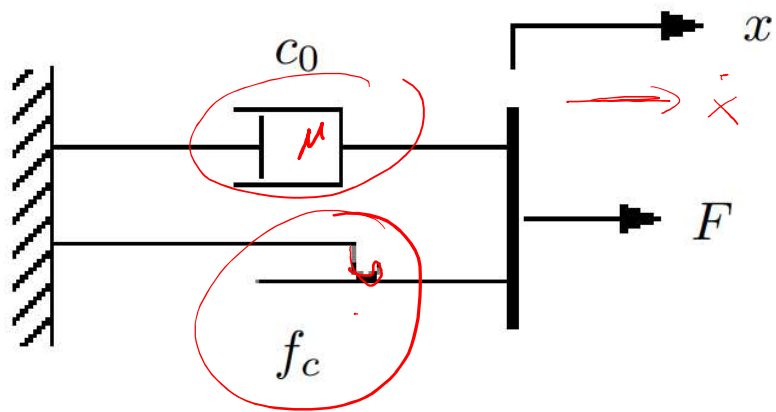
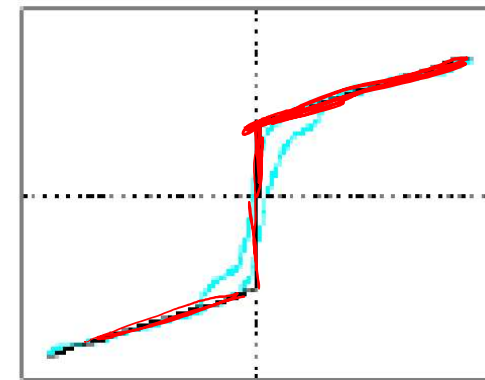

Figure 3: Bingham model of MR fluid (a) and effect of the magnetic field on the yield stress (b).

# Lumped parameter model 1



Force



Velocity

$$F = f_c + c_0 \dot{x}$$
$$\tau = \tau_c + m \dot{v}$$

# Lumped parameter model 2

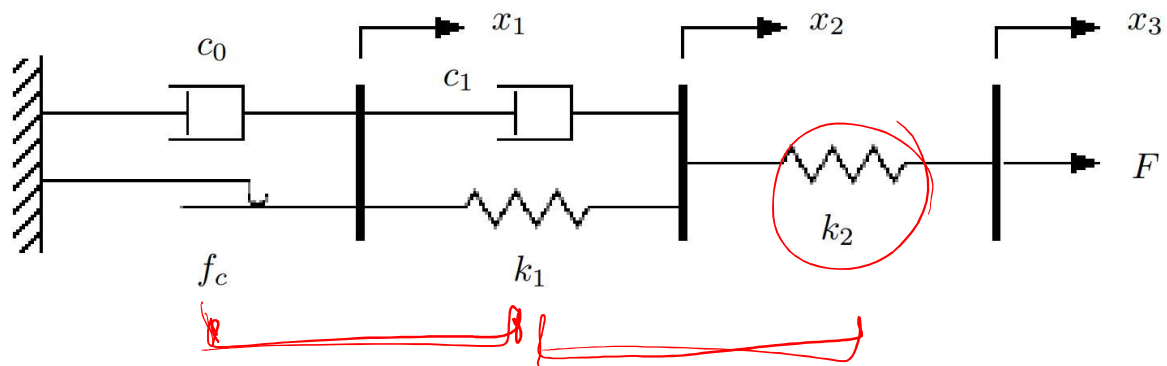

Force

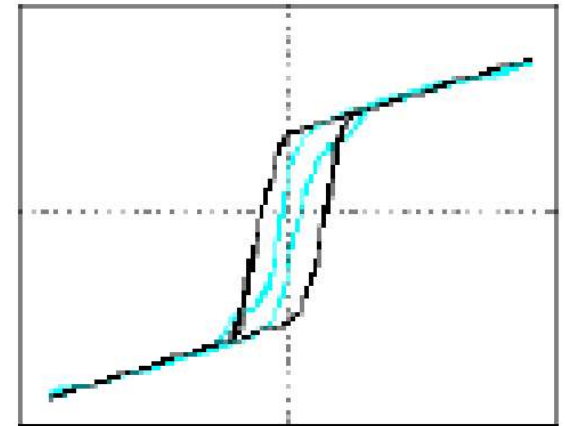

Velocity

# Working modes

- a) **Flow-mode** exploits the flow between *two fixed walls*, the *magnetic field is normal to the flow direction* and is typical for **linear damper applications**.
- b) **Shear-mode** is mainly used in **rotary application** such as brakes and clutches and the fluid is constrained between two *walls which are in relative motion* with the *magnetic field normal to the wall direction*.
- c) **Squeeze-mode** is used mainly for **bearing applications**, is able to provide *high forces and low displacements* having the magnetic in the same direction of the applied force.

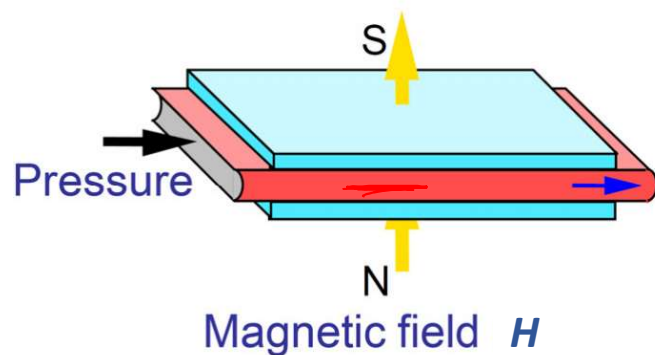

(a)

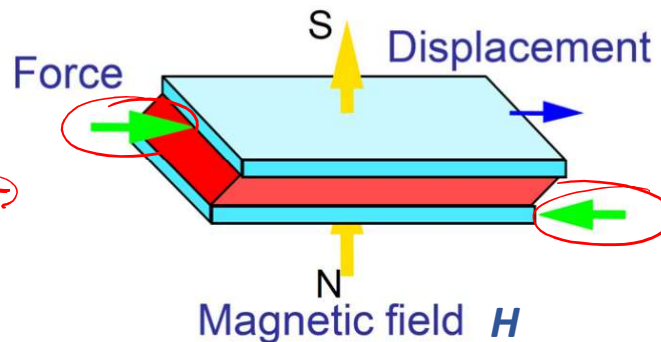

(b)

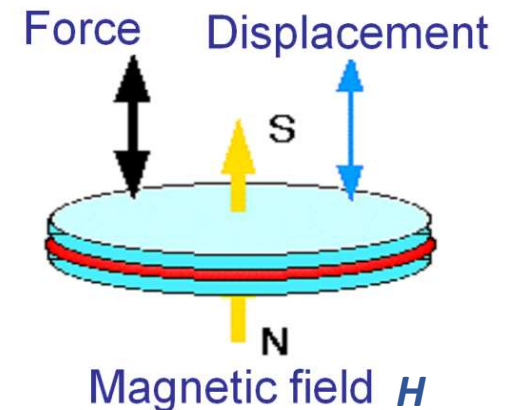

(c)

# Calcolo coefficiente smorzamento

Shear-mode operation

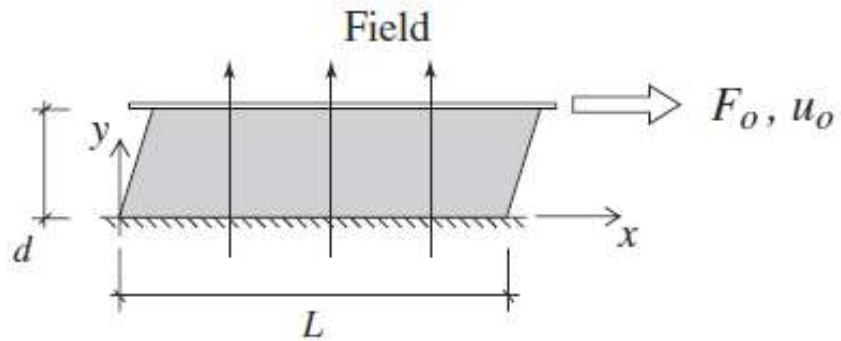

$$c = c_0(1 + Bi)$$

$$c_{0\_SM} = \mu\alpha$$

Flow-mode operation

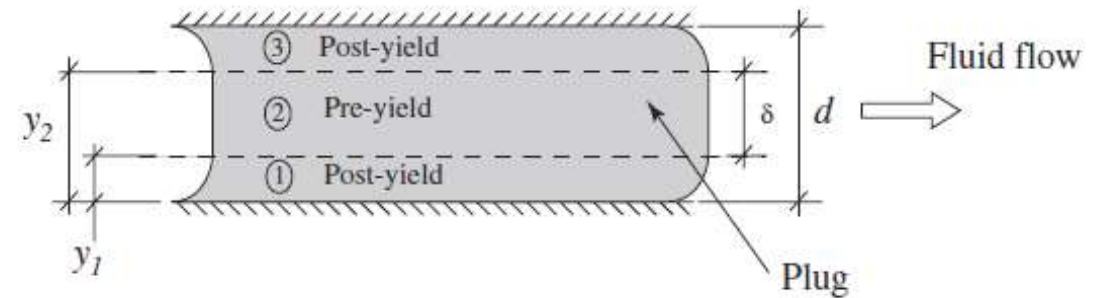

$$c = c_0 \frac{Bi}{6\delta}$$

$$c_{0\_FM} = 12\mu\alpha$$

# Commercial MR & Limitations

MRF COMMERCIALI	PERCENTUAL E IN VOLUME DI PARTICOLATO	MATRICE FLUIDA	DENSITÀ [ g/cm <sup>3</sup> ]
MRX-126PD	26	Olio di idrocarburi	2.66
MRX-140ND	40	Olio di idrocarburi	3.64
MRX-242AS	42	acqua	3.88
MRX-336AG	36	Olio di silicone	3.47

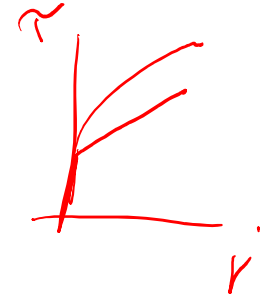

- High density, due to presence of iron, makes them **heavy**. However, *operating volumes are small*, so while this is a problem, it is not insurmountable.
- High-quality fluids are **expensive**.
- Fluids are subject to shear-thickening (non linear behaviour) after prolonged use and need **replacing**.
- **Settling of ferro-particles** can be a problem for some applications.

# Example of application: Controllable Linear Dampers

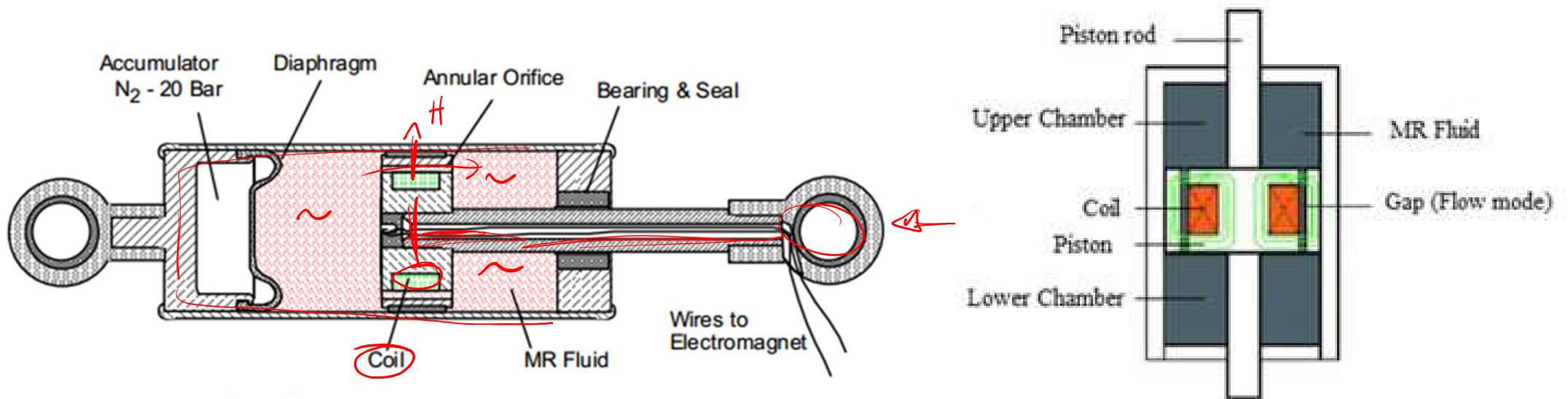

The **desired level of damping** can be obtained *varying the magnetic field in an orifice between two separated MR fluid chambers*. The orifice acts like a magnetic valve for the fluid, regulated by the current and thus exploits the MR fluid in **flow mode**.



# Ferrofluids (FF)

Differently from MR fluids, FF particles are primarily nanoparticles that are *suspended by Brownian motion* and generally will not settle under normal conditions.

Ferrofluid is **superparamagnetic**, which means that they *behave like magnets only in the presence of a magnetic field*.

*This property is found only at the nanoscale. At the macroscale, ferromagnetic materials are permanently magnetic.*

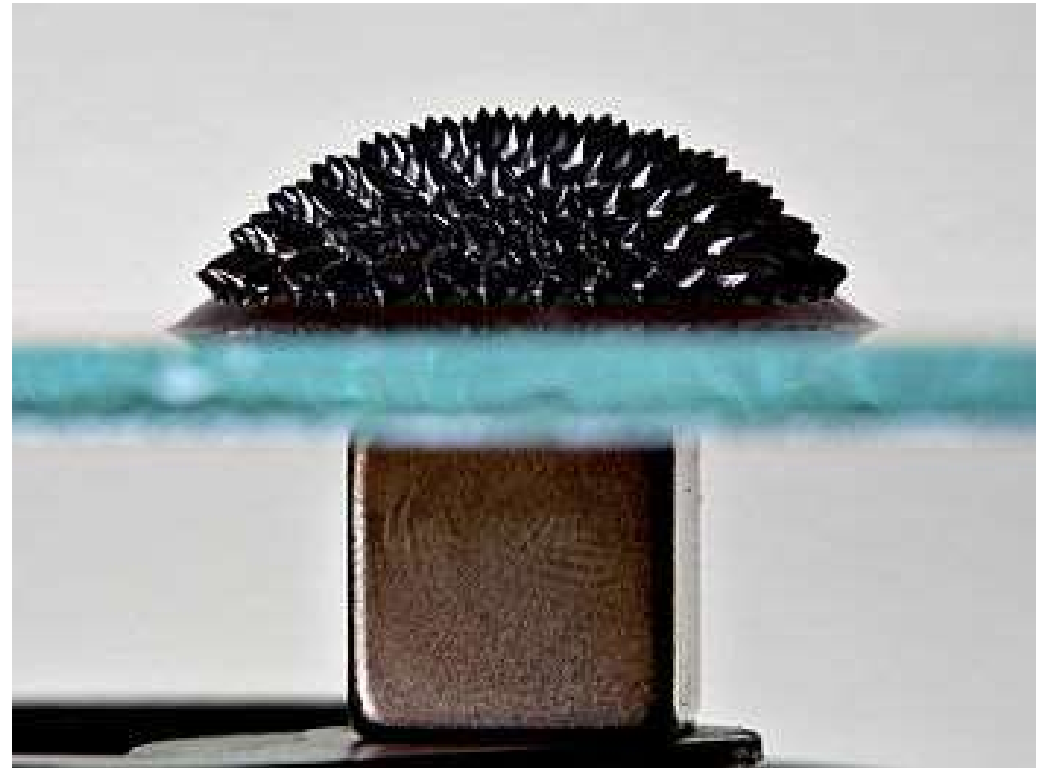





# FF applications

FF **keeps its fluidity** even if subjected to strong magnetic fields.

Most applications of magnetic fluid are based on the following of its *properties*:

- It **goes to where the magnetic field** is strongest and stays there;
- It **absorbs electromagnetic energy** at convenient frequencies and *heats up*.

## *Biomedical Applications:*

- 1) Magnetic drug targeting; 
- 2) Hyperthermia; 
- 3) Contrast enhancement for Magnetic Resonance Imaging; 
- 4) Magnetic separation of cells. 



# FF - Biomedical Applications

## 1. Magnetic drug targeting

a **ferrofluid bounded drug** is injected in a cancer tumor and there it is kept during some time ( $\approx$  one hour) by a suitably **focused magnetic field**.

The amount of drug necessary is much less than what would be necessary if it were dispersed in the whole body (*dose reduction*). When the magnetic field is turned off the *not metabolised* drug will disperse in the body, but, since the total amount is very small, there will be practically no side effects.

## 2. Hyperthermia

The property of ferrofluids of **absorbing electromagnetic energy at a frequency that is different from the frequency at which water absorbs energy** allows one to **heat up a localized portion of a living body, where ferrofluid has been injected**, for example a **tumor**, without heating at the same time the surrounding parts of the body.

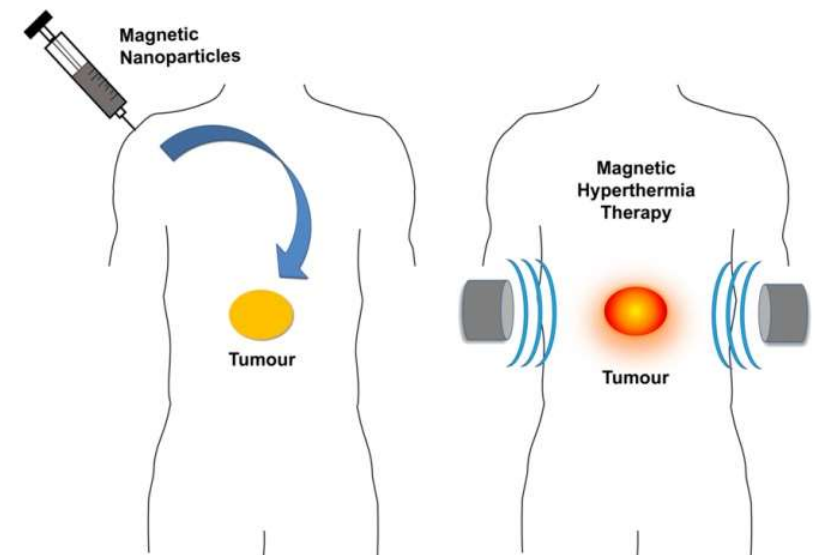

# FF - Biomedical Applications

## 3. Contrast enhancement for Magnetic Resonance Imaging (MRI)

If magnetic particles from a biocompatible **FF** are **selectively** absorbed by some kind of tissue, this will become **very clearly visible by MRI**.

**Dextran coated iron oxide NP** are biocompatible and are excreted via the liver after the treatment. They are selectively taken up by normal cells with respect to *tumor cells, which* do not have an effective reticuloendothelial system. This makes them distinguishable from the surrounding healthy cells.

## 4. Magnetic separation of cells

It is a two-step process: 1) **fixing a magnetic particle** to the desired biological entity (**antibodies**), and 2) **pulling the magnetic particles**, together with their "prey" out of the native environment by the action of a magnetic field gradient.

Example: **cleaning bone marrow from cancer infected samples**, aiming to use the purified samples to be implanted again in the same person. In this case, magnetic nanospheres are coated with monoclonal **antibodies having an affinity for the tumor cells**. When marrow removed from the patient is put in contact with the coated spheres in a liquid solution, the tumor cells selectively attach to the surface of the spheres, which are then magnetically separated from the solution.

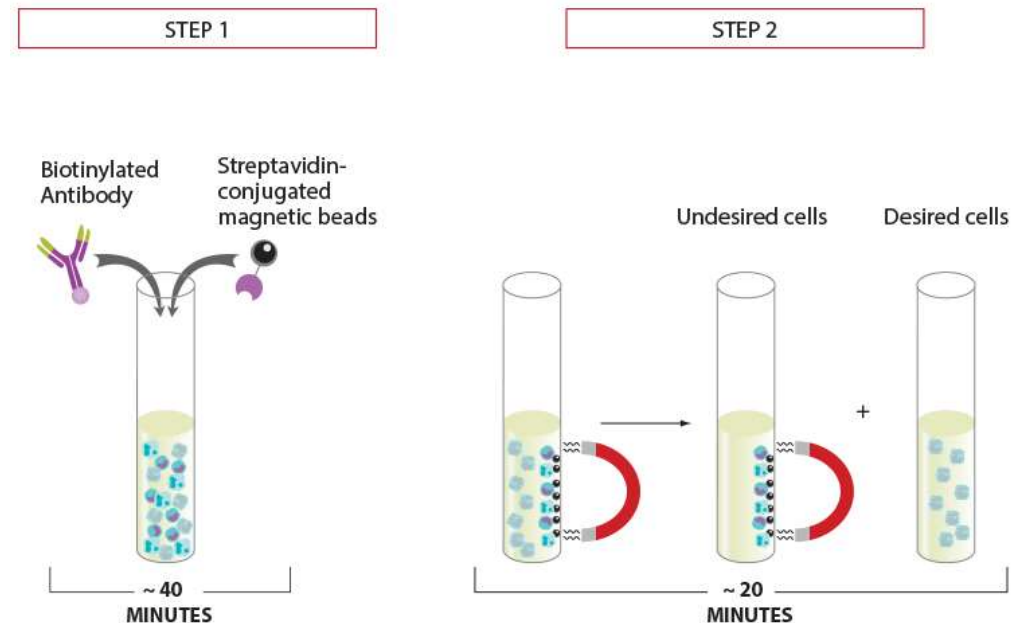

**Ferrogels:**

# Active scaffolds for on-demand drug and cell delivery

Xuanhe Zhao<sup>a,b</sup>, Jaeyun Kim<sup>b</sup>, Christine A. Cezar<sup>b</sup>, Nathaniel Huebsch<sup>b,c</sup>, Kangwon Lee<sup>b</sup>, Kamal Bouhadir<sup>d</sup>, and David J. Mooney<sup>b,1</sup>

<sup>a</sup>Soft Active Materials Laboratory, Department of Mechanical Engineering and Materials Science, Duke University, Durham, NC 27708; <sup>b</sup>School of Engineering and Applied Sciences and Wyss Institute, Harvard University, Cambridge, MA 02139; <sup>c</sup>Harvard-Massachusetts Institute of Technology Division of Health Sciences and Technology, Cambridge, MA 02139; and <sup>d</sup>Department of Chemistry, American University of Beirut, Beirut 11-0236, Lebanon

Edited by Alexander M. Klibanov, Massachusetts Institute of Technology, Cambridge, MA, and approved November 11, 2010 (received for review June 4, 2010)

Porous biomaterials have been widely used as scaffolds in tissue engineering and cell-based therapies. The release of biological agents from conventional porous scaffolds is typically governed by molecular diffusion, material degradation, and cell migration, which do not allow for dynamic external regulation. We present a new active porous scaffold that can be remotely controlled by a magnetic field to deliver various biological agents on demand. The active porous scaffold, in the form of a macroporous ferrogel, gives a large deformation and volume change of over 70% under a moderate magnetic field. The deformation and volume variation allows a new mechanism to trigger and enhance the release of various drugs including mitoxantrone, plasmid DNA, and a chemokine from the scaffold. The porous scaffold can also act as a depot of various cells, whose release can be controlled by external magnetic fields.